



Schuylkill Haven, PA.

“SAVE THESE INSTRUCTIONS” HOT WATER BOILERS

Safety, Installation and Operating
Instructions enclosed.

**Please read and understand these following instructions. If
instructions are not followed; a fire may result causing
property damage, personal injury, or even death.
Installations must be performed by a qualified installer.
Follow All local building and zoning codes.**

SAVE THESE INSTRUCTIONS

Instruction Must be with the owner of the boiler

Keystone Manufacturing Company
60 Keystoker Lane
Schuylkill Haven, PA 17972
(570) 385-3873
info@keystoker.com

About Us

Keystoker had its inception in 1946.

Two electrical engineers saw the need for a way to conveniently burn anthracite coal, which was plentiful, but heating with coal had a bad reputation of being dirty and requiring maintenance several times a day. Our engineers developed an automatic stoker unit equipped with a coal hopper that held enough fuel for several days. This allowed the coal to be cleanly burned and without frequent maintenance. They then saw the need to make a hot water boiler specifically designed to burn coal and built them in multiple sizes to meet our customers' needs.

As prices of energy continued to escalate, Keystoker continued its research. Over 70 years of research has developed a patented feed-in system, a patented flat grate, and a patented thermal heat exchange, which has produced the highest efficiency possible.

Keystoker --- Made in America with American Technology and utilizing American resources is now known internationally for its simplicity, quality, and dependability, all this and still an economical price.



Table of Contents

Company Introduction	2
SAFETY	4
UL Label	4-5
Precautions & Definitions	6
General Safety Statement	6
Safety	7-9
Hot Water Specification Chart	10
Installation	11
Boiler Placement	11
Set Up Boiler	12
Supply & Return Piping	12
Boiler Fill & Domestic Water Piping	12-13
Installation & Piping of Accessories	13
Jacket/Shroud & Stoker Unit Installation	13
Control Installation & Electrical Wiring	14
Stack/Flue Pipe & Barometric Damper Installation	14
Initial Start Up & Water filling	14
Fuel Type	14
Operation	15
Start Up	15
Check Draft	15
Initial Coal Feed	15
Diagram 1 -Continuous Operation	16
Diagram 2 – Intermittent Operation	17
Figure 2 – Initial Main Combustion Air Setting	18
Component Description & Operation	19
Figure 4 – Stoker Unit components	20
Controls Descriptions	20-21
Figure 5 - Typical Control Arrangement	21
Setting Draft	22
Setting Timer	23
Maintenance	23
Testing Controls & Safety Devices	23
Aqua Stat	23
Low Water Cut Off	23
High Limit w/ Manual Lock Out	23
Safety Relief Valve	23-24
Cleaning & Lubrication of Boiler	24
Ash Pan Emptying	24
Troubleshooting Guide	25
Diagrams	26
Wiring Diagram-Boiler	26
Wiring Diagram-Boiler: Coal Oil Option	27
ISO Plumbing Diagram Single Boiler	28
ISO Plumbing Diagram 2-Boilers	29
Typical Zone Valve Wiring Diagrams	30
Boiler Major Components	31
Parts Ordering	32
Warranty	32
Check list	33
Notes	34



**Tested per UL 2523, first edition
CAN/CSA-B366.1, January 2011**

MH60075 SOLID FUEL-FIRED BOILER ASSEMBLY

Keystone Manufacturing Company

60 Keystoker Lane
Schuylkill Haven, PA 17972
Phone 570-385-3873

Models: KAA-4, KFL-6, KA-6, KB-8, KC-10, KD-12, KE-15, KF-18, KG-22

Serial Number _____
Date manufactured stamped on data plate attached to boiler

BURN ONLY ANTHRACITE COAL

POWER SUPPLY- 120V, 60 Hz, use not less than 14 AWG wire and not less than 15A breaker. Total power usage by unit 5.5A. Installation to be performed only by a qualified heating professional. Follow manufacturer's instruction manual for installation and operation of the unit. Follow manufacturer's instruction manual for wiring diagrams and field wire connections. Use copper conductors only. Use only chimney parts as referenced by manufacturer's installation manual.

DO NOT CONNECT THIS UNIT TO A CHIMNEY FLUE THAT SERVICES ANOTHER APPLIANCE

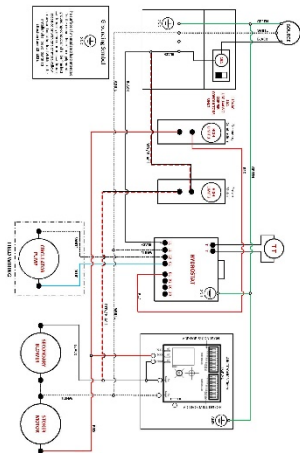

Installation Clearance from combustible material:

Fire/Ash Door	30 inches
Plain side	6 inches
Stack End	18 inches
Hopper End	6 inches
Top	12 inches
Floor	Non-combustible (preferably concrete)

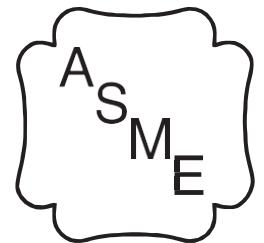

H

**DO NOT ATTEMPT TO LIGHT A FIRE WHEN THERE IS OIL VAPOR PRESENT.
DO NOT BURN GARBAGE, GASOLINE, NAPHTHA, ENGINE OIL, OR OTHER INAPPROPRIATE MATERIALS.**

Hot water boiler shall not exceed 160 psig. (1103 kpa) and a temperature exceeding 250 deg.F.(121deg.C.).

For safety, keep fire and ash pit doors tightly closed.

The heat exchanger, flue pipe and chimney must be cleaned regularly to remove accumulated fly ash.

Ensure that the heat exchanger, flue pipe and chimney are cleaned at the end of the heating season to minimize corrosion during the summer months.

The appliance, flue pipe and chimney must be in good condition.
 These instructions also apply to a draft inducer.
 Refer to owner's manual.
 Do not alter this equipment in any way.

Minimum allowable draft setting is -.01 inches of water column and the maximum allowable draft setting is -.04 inches of water column taken over the fire in a predrilled hole in the fire door.
 The maximum ampere rating of the circuit is 15A and the minimum ampere is 10A.
 The essential parts of the boiler, stoker unit, jacket, controls, exhaust pipe and draft regulator.
 Suitable for potable water and space heating.
 Use copper conductors only for field wiring.
 For power supply connections use 14 AWG or larger wires, acceptable for at least 105 degrees "C".
 For after loss of power operation, turn power to the off position and re-light fire.

WARNING RISK OF FIRE

Danger risk of fire and explosion. Do not burn garbage, gasoline, drain oil, or other flammable liquids.
 Do not operate with flue draft exceeding -.04 inches of water column.
 Do not use chemicals to start unit firing.
 Do not burn garbage, gasoline, fuel oils, or other flammable liquids or materials.
 Do not operate while loading fuels or removing ash.
 Do not store fuel or other combustible material within marked installation clearances.
 Inspect and clean the flues and chimney regularly.
 Caution hot surface.
 Hot surfaces keep children away.
 Do not touch during operation.
 Danger-to-avoid injury from moving parts shut off the equipment before working on unit.
 Replaceable fuse 15 AMP.
 In the event of a "runaway fire", move on/off switch to the off position, turn hot water on using a spicket/faucet and let run until the boiler cools down.
 The potable water heater shall not be connected to any part of the heating system or appliance that is for non-potable water. Toxic chemicals such as boiler treatment, oils and dirt may be present and shall not be introduced into the potable water heater.

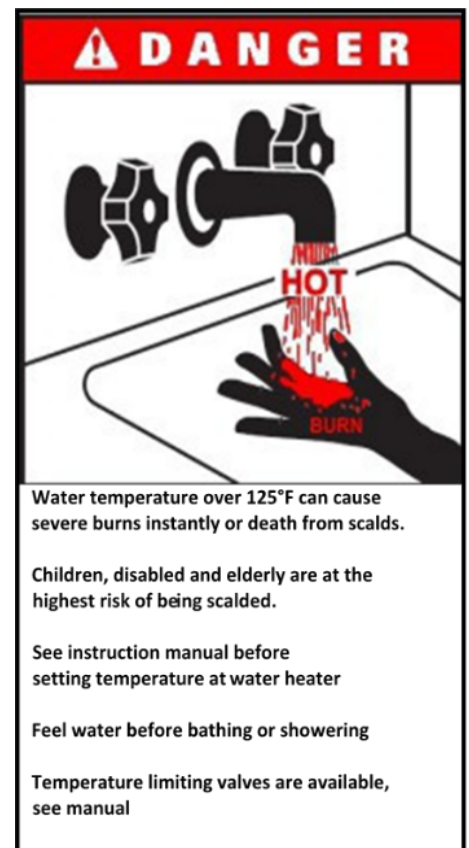

Safety

Precautions & Definitions

Our boilers have been designed for safe and reliable operation when properly used and maintained in accordance with instructions contained in this manual. A stoker boiler is a precision system that if not properly installed or maintained can be hazardous, cause burns, electrical shock or even loss of life. Keystoker shall not be liable for physical injury, damage to property or death caused by a failure to observe the instructions in this manual.

Please note the following symbols are used to denote special attention within this manual:



Burn & Scalding Hazard. Operating procedure, practice etc. which, if not correctly followed, could result in burns or scalding from hot water.



Electrical Hazard. Particular care must be taken when electrical power source to the unit is energized.



Warning. Operating procedure, practice etc. which, if not correctly followed, could result in personal injury.



Caution. Operating procedure, practice etc. which if not followed could result in damage or destruction of unit.



Fire. Operating procedure, practice, etc. which if not followed could result in severe burns, bodily harm, loss of life and property damage.



Death. Critical situation or operation of unit that may cause death.

General Safety Statements:

- Thoroughly read and understand all instructions
- Always leave this manual with the owner of the boiler.
- A carbon monoxide (CO) detector has been supplied with your boiler.
 - **The CO Detector needs to be plugged in.**
 -  CO is colorless, odorless & tasteless gas that can be deadly if not monitored or detected properly.
- Danger risk of fire or explosion. Do not burn garbage, gasoline, drain oil, or other flammable liquids. Do not use chemicals or fluids to start fire.
- Boiler surfaces may be hot while in operation. Keep children away. Do not touch during operation
- Do not connect this unit to a chimney flue serving another appliance
- Please follow all local building and Zoning ordinances
- Use the proper fuel type as noted in this manual

Safety

Only fill hopper to the maximum fill line, **Do not fill with wet coal.**



- Coal should not overflow top of the hopper.
- Do not store fuel within the recommended installation clearance for proper ash removal and refueling the boiler.
- Fuel can be store as followed, large coal bin, buckets or bags.
- Solid fuel burning appliances need to be cleaned frequently, soot and ash can accumulate restricting heated air and exhaust flow through the boiler.
- The type of fuel that will be burned is **Anthracite coal**. Anthracite **does not** create creosote, but does Create soot or a fine fly ash that will accumulate in stack pipe.
- **Furnace and stack must be cleaned at least once a year. Stack may need to be cleaned more often depending on coal consumption.**
- Chimney should be as per NFPA 211- 316 Stainless Steel Liner or Brick Lined and in good condition, height requirement is 16 feet.
***For Canadian installation: as per NFPA 211- Chimney must be 304, 316, 404, 443 stainless steel.**

- Maximum flue draft shall not exceed -.06 inches of water column. Exceeding maximum draft will result in an out of control burn.
- Make sure boiler room is large enough for adequate combustion air. If the room is too small, an outside air vent must be used.
- All control and electrical covers shall be installed before being energized. Do not remove covers for service or maintenance unless power supply has been shut off. This could be done with the supply breaker or by removing the fuse. Test with multimeter to ensure no voltage is present.
- Fill hopper using a bucket or shovel, bags can be dumped directly into hopper if bags are not water logged. Care should be taken when filling hopper, safety glasses and gloves are recommended when doing so. Do not overfill hopper.
- A carbon monoxide detector has been supplied with your boiler. You **must** plug it in.

THE BURNING OF ALL FOSSIL FUELS GENERATES CARBON MONOXIDE GASES. CARBON MONOXIDE GASES ARE TOXIC. CAN CAUSE DIZZINESS, FATGUE, NAUSIA AND DEATH.

To prevent toxic carbon monoxide gases from entering the home or building certain precautions must be taken.

- **Ash Tubs** must be emptied on a regular basis to prevent ashes from overflowing into the ashpit area of the boiler. Excessive ash accumulation may obstruct air flow to chimney, preventing gases to be drawn up the chimney.
- Ashes should be collected in a steel container inside the boiler. When container is full it should be moved outdoors or place on a noncombustible surface.

“Caution” ash tub will be HOT. Gloves will be necessary to remove ash tub from boiler.

- Before removing ash tub, turn power to the off position, open ash door. Using a good pair of gloves remove full ash tub, place tub on a noncombustible surface. Slide an empty into boiler and turn power switch on.
- Other waste shall not be placed or stored in ash containers.
- **Disposal of ashes:** Ashes should be collected in a metal container. When container is full it should be removed from the boiler and put on a noncombustible surface or the ground well away from all combustible materials, pending final disposal. If ashes are disposed of by burial in soil or otherwise locally dispersed, they should remain in the container until all cinders have cooled thoroughly cooled.
- **Fire Door and Ash Door** must be closed at all times during operation.
- **Hopper:** It is necessary to keep some coal in the hopper while boiler is in operation.
- **Fuel:** Burn Rice or Buck wheat Anthracite coal only.

Safety

- Boiler must be installed on a noncombustible surface (concrete, fireproof floor pad, ect).
- **Prolonged Power outages**, during a prolonged period of time without power steps should be taken to ensure that the boiler does not freeze. Circulating the water to prevent freezing or draining the system before freezing. If have become frozen checks for breaks in the piping and repair before starting the boiler. If the boiler temperature is extremely low, boiler controls should be turn down to the lowest settings. Light the fire at let the system heat up to lowest setting, let circulators run and check system for leaks. If system is good turn controls to regular settings.

Hot Water Boiler Specification Charts

Model No.	BTU / Hour (Nearest Thousand)		Hopper Capacity (Lbs.)	Stoker Data		Relief Valve MAX PSI
	Net	Gross		Model	# of Grates (3" x 14")	
KA-4	102	120	200	AA	3" X 12"	30
KFL-6	116	132	275	AA	3" X 12"	30
KA-6	122	144	275	A	3	30
KB-8	163	192	315	B	4	30
KC-10	204	240	450	C	5	30
KD-12	245	288	525	D	6	30
KE-15	306	360	525	E	7	30
KF-18	367	432	525	F	8	30
KG-22	448	528	585	G	9	30

Model No.	Gallons of Water	Smoke Outlet Size	Width	Length	Height
KA-4	34	6"	22"	34"	47"
KFL-6	55	8"	24"	40"	52-1/2"
KA-6	55	8"	24"	40"	52-1/2"
KB-8	74	9"	29"	42"	55"
KC-10	86	10"	31"	44"	56"
KD-12	96	10"	31"	50"	55"
KE-15	122	12"	33"	55"	57"
KF-18	154	12"	33"	54-1/2"	61"
KG-22	188	14"	37"	62-1/2"	61"

- Chimney should be as per NFPA 211- 316 Stainless Steel Liner or Brick Lined and in good condition, height requirement is 16 feet.

***For Canadian installation: as per NFPA 211- Chimney must be 304, 316, 404, 443 stainless steel.**

Installation

Boiler Placement

- Boilers must be installed on a noncombustible floor. Keystoker boilers are available with fire door on the right or left side. When you stand at the stoker end of the boiler and look directly over top of boiler toward stack end, you may choose to have a fire door on the right or left side of boiler. Selecting a position to make this door accessible is important. When door side must be placed toward a wall, 30" clearance is recommended for easy fire and ash door access. Clearance from wall at stack end should be 18" to permit removal of water heating coil if necessary and easy access for removal and cleaning of stack pipe. Clearance on blank and hopper sides should be 6". Clearance from the top of the boiler to a combustible is 12". Refer to Figure 1. For industrial and commercial installations please follow local codes.

Requirement for combustible floor protection. 16" in front of fire/ash door 8" on each side of doors. At least 2" on either side a chimney connector.

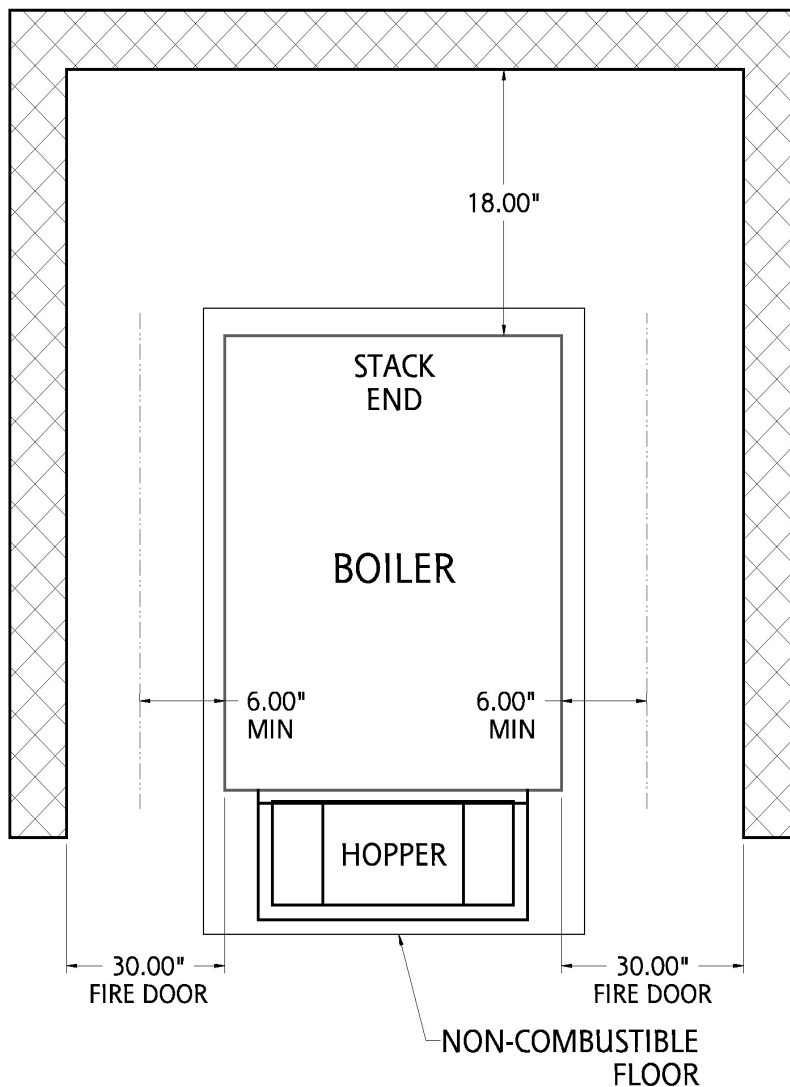

FIGURE 1

Setup of Boiler

1. Place boiler in desired position.
 2. Place steel shims or bricks under each corner of boiler to allow an air space, to prevent moisture from accumulating and rusting base of boiler. The brick should stick out 2" Past each corner so the jacket has adequate support.
 3. Using a level, plumb stoker end of the boiler, adding steel shims as necessary. Failure to do this will change pitch on stoker unit and may have adverse effects when burning coal.
 4. Using a level, check top of boiler from side to side, adding shims as necessary to level boiler. Do not place shims completely under boiler. Allow 1" to 2" of shims to extend out from under the boiler. Shims are used as a base to set insulated jacket upon.
- Chimney should be as per NFPA 211- 316 Stainless Steel Liner or Brick Lined and in good condition, height requirement is 16 feet.
***For Canadian installation: as per NFPA 211- Chimney must be 304, 316, 404, 443 stainless steel.**

Supply & Return Piping System



The top of the boiler has at least 4 openings. The largest opening is the feed line to your radiation. Since this outlet has a drop tube welded inside the boiler, you must use for your radiation supply line. Even though it may be necessary to reduce down to a smaller size, we recommend starting with 1 1/4" pipe and installing a 1 1/4" x 1 1/4" x 1" tee in supply line to be used for a by-pass loop. You may now make your piping connections from feed outlet on boiler to flow valve.



You may use either of the large openings on the bottom of the stack end of the boiler as your return. Select the side that will allow convenient access to the circulator for future servicing. Install return piping and circulator, again referring to the location of by-pass loop. The 1 1/4" x 1 1/4" x 1" tee must be installed below circulator. Refer to Diagram 1, page 25. The circulator can be mounted to the feed line to push the water, instead of pulling the water if it was installed on the return line.

Install by-pass loop as per ISO Plumbing Diagrams, page 24, with 1" pipe size. Place a tee, 1" x 1/2" F x 1", in by-pass loop allowing the immersion well, for the 4006B Honeywell Hi-Limit control, to extend into the full-water flow after its installed.

Over 50 years of installation experience has proven to us that the above-mentioned by-pass loop is absolutely necessary for optimum performance of your heating system

Install a boiler drain valve in the other large opening at bottom of boiler.

Boiler Fill & Domestic Water Piping

1. Refer to Diagram 1, Pg. 28. Install 1/2" male adaptors in both fittings on domestic water coil.
2. Install a 1/2" male adaptor onto the 1/2" fittings on the top of the end of the boiler to be used for a boiler water fill.

3. Solder a piece of pipe onto the ½" adaptor to extend the pipe outside of the jacket.

NOTE: Before proceeding with connections for piping of boiler fill and domestic water,



INSTALL stack end of insulated steel jacket NOW. Then you may proceed with completion of domestic piping and installation of necessary valves.

4. Install a domestic water mixing valve, Honeywell AM-1 series **not included** with boiler. Install as per manufacture instructions.
5. Automatic fill valve is **not supplied**, install as per manufacture instructions.
6. Install a PH 5 expansion tank on the cold-water line as per manufacturer instructions.

Installation & Piping of Accessories



1. A ¾" 30 lb. ASME approved relief valve (supplied) must be installed in ¾" fitting on top of boiler, turning discharge to the side and hard pipe it to 6" above floor. End of relief valve discharge pipe should be cut on an angle so no valves, caps or plug can be installed. **Discharge pipe must be open-ended.**

2. Install altitude gauge (temperature/ pressure gauge) (supplied)



3. Connect expansion tank directly to remaining fittings on top of the boiler, NOT to any other part of the heating system. Install a 1/2" ball valve in pipe going to expansion tank with direction marker on valve pointing toward the expansion tank. If an air scoop is used, you must have an air bleeder on top of the boiler.

4. Install immersion wells for the (2) high limit controls and (1) for the triple aqua stat, in ¾" fittings on side of boiler above fire door. (supplied). Install the triple aqua stat well closest to the hopper. The triple aqua stat well has an insulated probe for the low water cutoff. Refer to figure 5 Pg. 21.



5. Apply **Hi-temperature silicone** or furnace cement to the boiler where the fire door frame is going to seal against. Then place fire door into boiler opening and secure by tightening handle open and put it through hole in handle on fire door and squeezing it closed.

Jacket & Stoker Installation



1. Install hopper end of jacket, then blank side, then fire door side; secure with #8 x 1" sheet metal screws provided. Install jacket top; secure with #8 x 3/8" sheet metal screws.

2. Stoker units are shipped pre-assembled; bottom of a stoker has a ¼" rod welded in place which must go inside the stoker opening. Place a thick smear of furnace cement or high temp silicone on flange of stoker and lift into place, securing with 3/8 x 1 ¼" square-headed bolts, washers, and nuts as provided. Insert bolts from the inside towards the outside. Install nuts on the outside for easy removal.



3. Set hopper into place. The hopper bottom should overlap stoker throat approximately 1". Since one hopper is used for varying sized stokers, it may be necessary to trim the

opening. Bend flange down to fit inside throat of stoker – be sure mechanism is free to operate.

Control Installation & Electrical Wiring



1. Install triple aqua stat onto its well being careful not to pinch the wire for connection.
2. Install limit switches onto the remaining (2) wells. Taking care not to damage the sensor probes.
3. After tightening triple aqua stat to well, connect well wire to terminal on circuit board. Your stoker must be on its own circuit. From main breaker to boiler use 14-2 wire with ground on a 15-amp breaker. Follow wiring diagram and any applicable UL and local code. **Use copper conductors only.**

Stack Pipe & Draft Control Installation



1. Stack pipe may now be connected from boiler to chimney, using as few elbows as possible. If stack pipe must be reduced in size, reduce stack at the chimney. It is important to run full size stack from boiler to chimney thimble.
2. Install barometric draft controls in first full section of stack closest to boiler. Follow instructions packed with draft control, making sure the draft control bearing are level and face of draft control is perpendicular to floor. Stack pipe must be 18" from any combustible material. In US it can be 26 gauge galvanized, or 26 gauge black stack pipe.

***For Canadian installation: Chimney must be 304, 316, 404, 443 stainless steel.**

Initial Startup – Water Filling



1. Fill system by opening boiler feed valve.
2. Open air vents on radiation one at a time until air is removed from system. Normal operating pressure on most heating systems is between 10 and 20 PSI. Automatic fill valves are factory set at 12 PSI. If an automatic fill valve is not used, then boiler feed valve must remain in normally closed position.
3. Open valve supplying water to domestic hot water coil, this valve must remain in the normally open position.
4. After bleeding off the system is complete, open valve supplying water to expansion tank, this valve must remain in the normally open position.

Fuel Type



1. Burn rice or buck sized Anthracite coal only.

Danger risk of fire or explosion. Do not burn garbage, gasoline, drain oil, or other flammable liquids. Do not use chemicals or fluids to start fire.

Operation

Startup



1. To start a fire, fill hopper with coal, reach in through fire door and pull coal down to cover entire grate area. Place kindling (charcoal supplied) into a full sheet of newspaper, crumple paper, and dig kindling deep into coal in the center of grate. Light newspaper with match and turn switch on. NEVER USE GASOLINE OR LIGHTER FLUID TO START FIRE. When kindling is burning well, place a few small shovels full of coal onto the fire.

Check Draft After Fire Startup



1. Allow boiler and chimney to warm up.
2. Insert draft gauge through pre- drilled hole in upper portion of fire door. See figure 6, Page 22.
3. Open air shutter (located on bottom of scroll between stoker motor and gear box about ½").
 - a. With the stoker motor running and feeding coal adjust the barometric damper until draft gauge reads (-.02) inches of water column.
 - b. If draft is less than a (-.02) inches of water column draft with the barometric damper closed, you must close the air shutter (between gear box & stoker motor) a little and recheck.
 - c. Repeat until you obtain a (-.02) inches of water column.
 - d. If the draft is higher than (-.02) inches of water column you must adjust the barometric draft regulator or main combustion air could be opened to allow more air into the fire chamber.
 - e. Move the weight on barometric regulator left or right to obtain the (-.02) inches of water column re-check the draft until you obtain a (-.02) inches of water column.

Initial Coal Feed

1. Advance **RED** nut all the way forward.
2. Adjust for coal type
 - a. Turn the **RED** nut counter clockwise 11 or 12 turns for burning rice coal.
 - b. Turn the **RED** nut counter clockwise 9 or 10 turns for burning buck wheat coal.
3. When boiler is running for about an hour under full load grates should have about 2" of dead ash before falling into the ash pan. If not fine tune coal feed adjust **RED** nut to obtain optimum setting.
4. Refer to Diagram 1 (Continuous Operation) and Diagram 2 (Intermittent Operation)

Diagram 1 – Continuous Operation

Depicts what fire should look like when the boiler calls for heat for extended period:

- A. Unburned fresh coal supply from coal hopper
- B. Burning Coals
- C. Ash on lower end of grate (around 2")

The actual length of burning coals will vary as boiler demand increases or decreases. If burning coals fall off grate, reduce coal feed by turning **RED** adjustment nut in a counter clock-wise direction 1 or 2 full turns. Wait at least 1 hour before making any more adjustments.

When the boiler is calling for heat, the large stoker motor will run continuously, but if the fire bed remains small, increase the coal feed by turning **RED** adjustment nut clock-wise.

Under normal draft conditions, when fire bed has reached its maximum length (with 2" of ash) flames should be touching top of interior boiler plate. If flame is not reaching top of boiler:

1. Fire bed may be too thick.
2. Reduce coal feed.
3. Burrs may be stuck on grate, scrape grate until it is smooth.
4. Not enough air flow, adjust air intake shutter on stoker unit. (see Check Draft section).

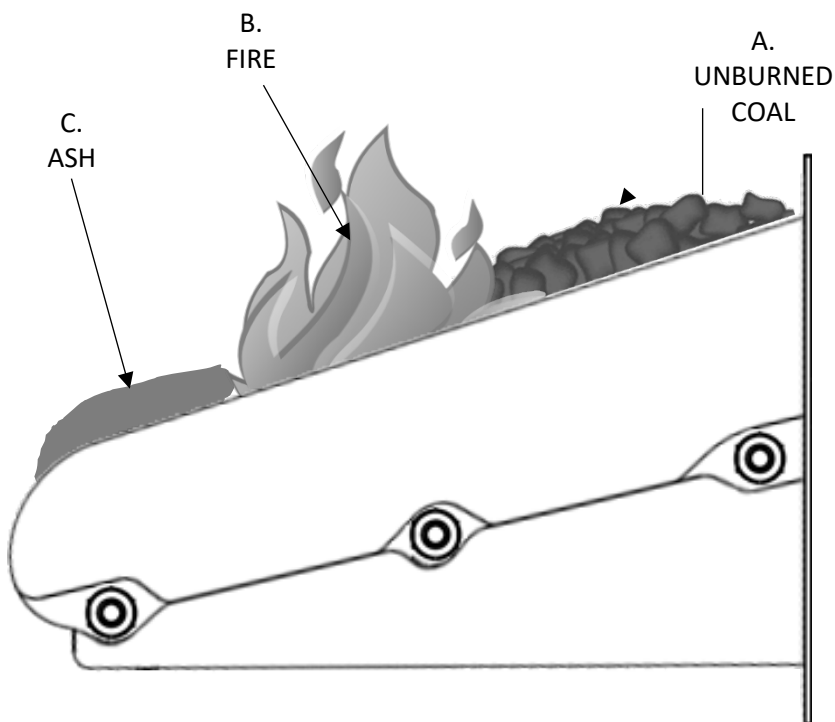

DIAGRAM 1

Diagram 2 – Intermittent Operation

Depicts what fire size should look like when the boiler has not called for heat for extended periods:



- A. Unburned fresh coal supply from hopper.
- B. Burning coal (about 1-1 ½" to 2") (little to no flames).
- C. Ash on lower end of grate

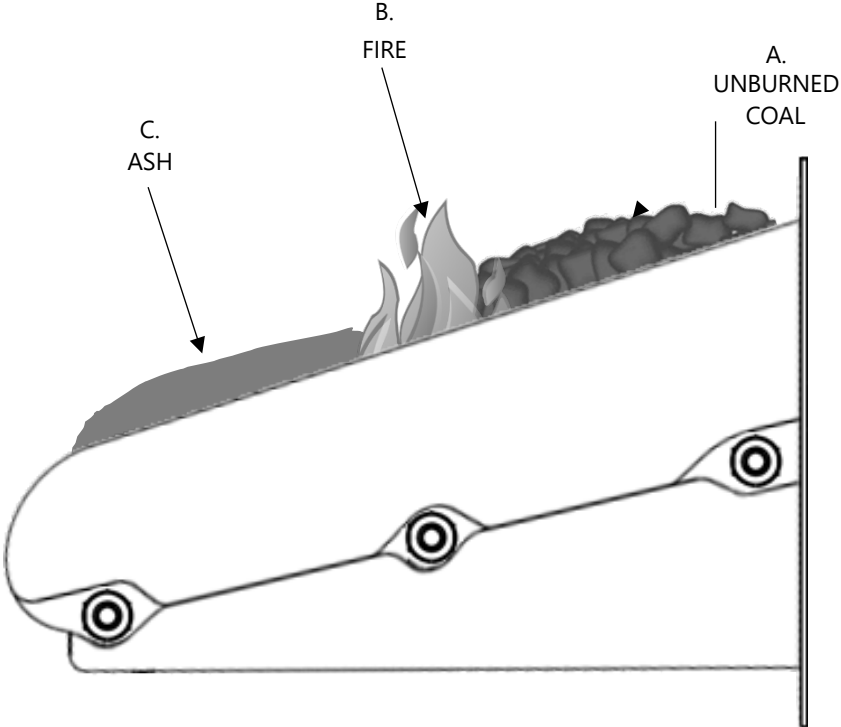

DIAGRAM 2

Initial Main Combustion Air Setting

The initial main combustion air setting is open about 1/2" may have to be adjusted with draft gauge. Refer to Figure 2.

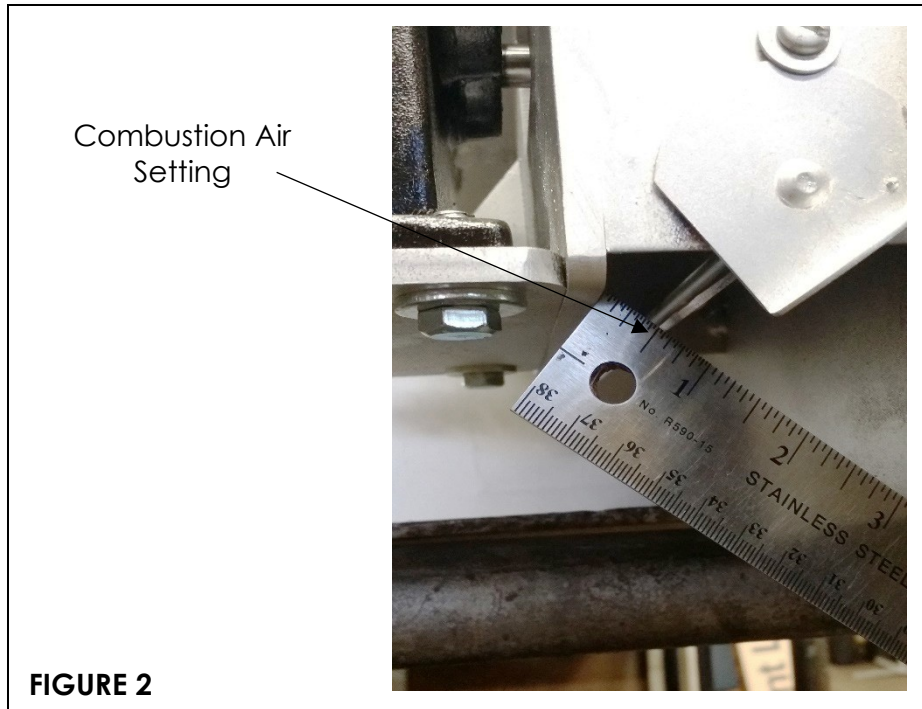

FIGURE 2

Combustion Blower Operation & Adjustment

To obtain a more complete burn out of coal during an idle fire, a small secondary blower motor is attached to the stoker unit. Setting of secondary combustion air 1/3 of the way open. THIS MOTOR IS DESIGNED FOR CONTINUOUS RUN.

1. When large stoker motor is running on demand, small blower will assist with combustion and heat output, by producing a more intense and hotter fire.
2. When demand cycle is completed, large stoker motor will shut off, and small secondary motor will continue to run. This will cause the coal that is already on the grate to burn, rather than to allow coal to smolder and die out in an unburned condition. This will achieve a cleaner ash, and allow more heat to be produced and absorbed into heating system.
3. During summer operation, the small combustion motor will force a small amount of air through grates at all times, which will cause the ash to become like powder. It also prevents the fire from going out. At the same time, it reduces the size of fire bed to approximately 1 1/2" to 2" which will prevent boiler water from becoming overheated.
4. Proper sizing of fire is obtained by turning red nut on feed control arm. Clockwise (CW) for more coal feed and Counterclockwise (CCW) for less coalfeed.
5. Location and final placement for red nut will be determined by size of coal you purchase. For rice coal, red nut might be turned down 12 turns for maximum setting, where, as for buckwheat coal, red nut might only be turned down 10 turns from maximum setting.

6. During winter operation, hot coals should never be pushed off end of grate. This would indicate that the coal feed needs to be reduced (CCW) or if during winter operation; fire bed is too small, turn red the nut (CW) to increase.
7. After coal feed adjustment is completed, if during summer, the water is too hot...DO NOT ADJUST COAL FEED. First reduce timer only. If fire goes out...DO NOT ADJUST COAL FEED. Increase timer only. If changing the timer does not solve the problem, then adjust 1 to turn off the coal feed.

Component Descriptions & Operation

Boiler Unit Components

- | | |
|----------------------------------|---------------------------------|
| 1. Stoker Body | 14. Pusher Bar Drive Shaft |
| 2. Side Rail Left K-2C | 15. Bearing K-17 |
| 3. Side Rail Right K-1C | 16. Feed Crank K-7 |
| 4. Grate K-15-1-L | 17. Feed Assembly Connector K-6 |
| 5. Grate K-15-2-L | 18. Feed Arm Nut |
| 6. Grate K-15-3-L | 19. Feed Arm Adjustment Nut |
| 7. Grate K-15-4-L | 20. Feed Latch K-12 |
| 8. Motor | 21. Feed Spring |
| 9. Blower Rotor | 22. Feed Bolt |
| 10. Bearing K-19 | 23. Drive Wheel K-5 |
| 11. Throat Strap K-18 | 24. Gearbox K-14 |
| 12. Pusher Bar Drive Yolk K-8-BC | 25. Coupling |
| 13. Pusher Bar K-9-BC | 26. Secondary Combustion Blower |

FIGURE 3

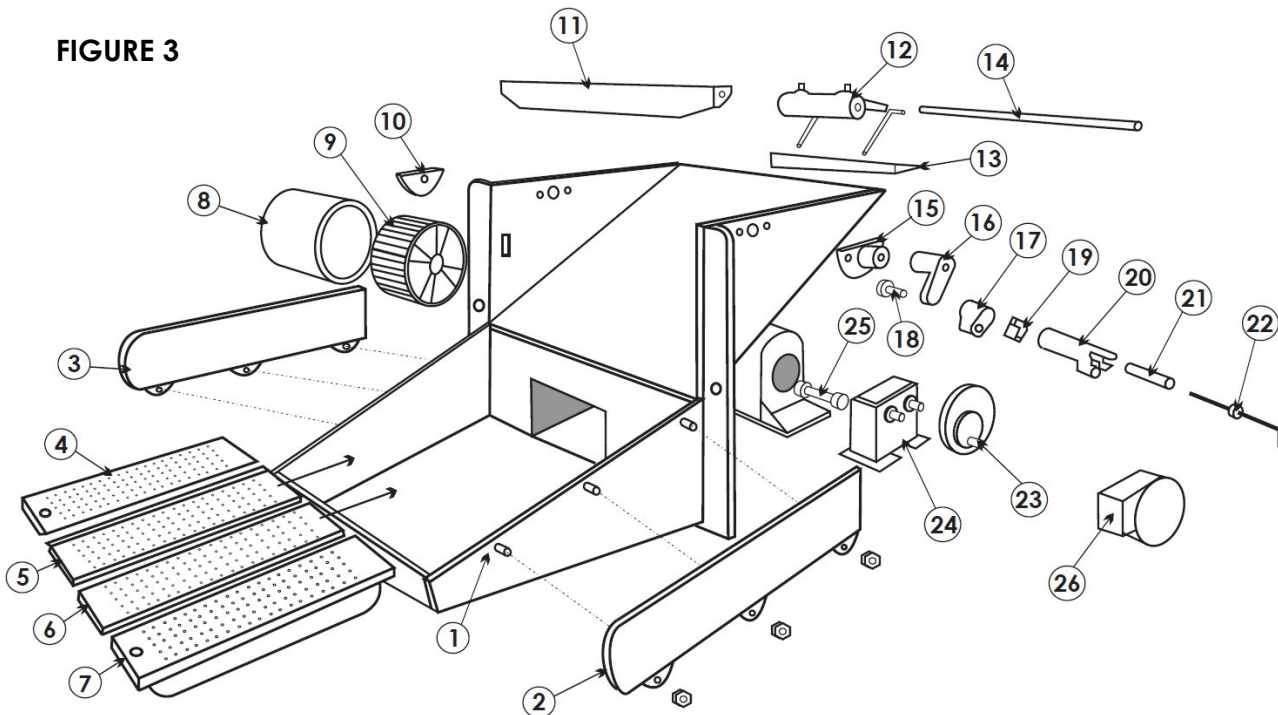

Boiler Unit Components – cont'd

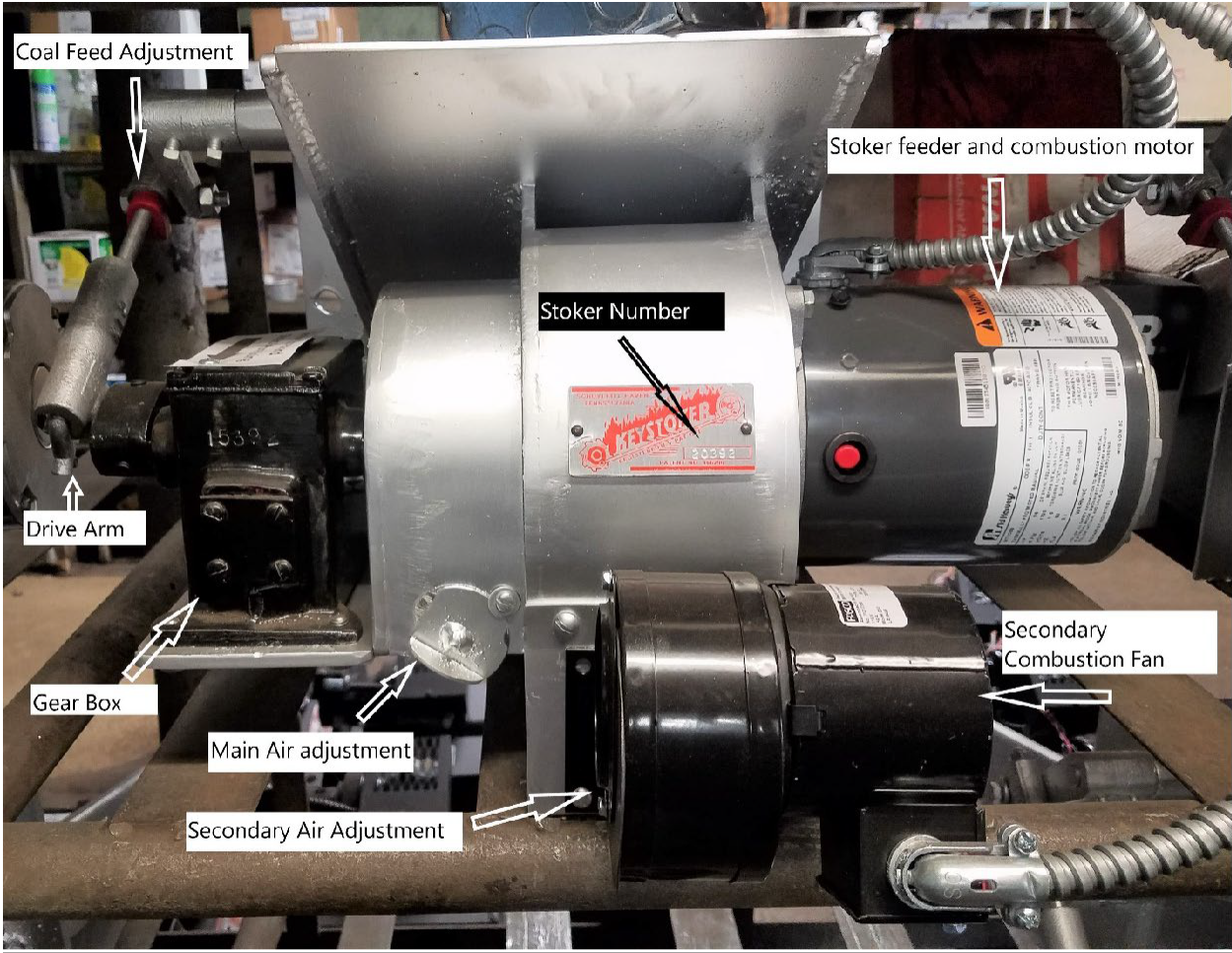

FIGURE 4

CONTROLS- Electrical controls insure proper operation of stoker unit and circulator. These controls consist of the following:

THERMOSTAT- Adjustable for desired room temperature. Set this to where the house is made comfortable.

TRIPLE AQUASTAT/Low Water Cutoff- Controls temperature of boiler and domestic hot water. It should be set at about 180° on high (Hi) and low (LO) maybe set at 160° for winter. Summer setting can be set at 160° for HIGH and 140° for LOW. A 20° minimum must be kept between HI and LO settings. Located above fire door closest to hopper.

TIMER- Controls stoker unit to maintain fire. It should be set initially to run about one minute every fifteen minutes. If idle fire is too small or boiler is going out you may need to add more time. If boiler is overheating you may need to decrease on time. To adjust timer, refer to page 23.

MAIN SHUT OFF SWITCH – Is located on the front of the boiler above the door and will shut off power supply to stoker unit and circulator.

FUSE – Located under main shut off switch under little cover and should never be larger than 15A Fuse-Tron.

HIGH LIMIT AQUASTAT #1 – This control should be mounted in port next to Triple Aqua stat. This should be set to 195 degrees. If boiler temperature becomes too high, this control will lock out and not let the feed motor feed anymore coal on the fire, the feed motor will not run again until the manual reset is pushed. And the fire will go out. If this condition occurs, refer to overheating.

HIGH LIMIT AQUASTAT #2 – This control should be mounted in the port next to High Limit #1. This should be set to 195 degrees. If boiler temperature becomes too high, this control will lock out and not let the secondary combustion blower motor and will not allow the secondary blower to blow air on the fire to keep it lit. The secondary blower motor will not run again until the manual reset is pushed. And the fire will go out. If this condition occurs, refer to overheating.

TEMPERATURE GAUGE – Located on top of boiler. Lower half indicates water temperature. Upper half indicates water pressure. In most cases water pressure, should be between 12 to 20 pounds.

MOTOR RESET BUTTON – Small red button located on outside of stoker unit motor in case of overloads, will trip outward, shutting off stoker motor. This can be reset by pushing red button inward. Should this trip again after being reset, **CALL** your local dealer.

COAL FEED ADJUSTMENT – Facing the stoker-hopper end of the boiler, you will see on the stoker an adjustable Drive connection threaded rod, attached to gear box. On this threaded rod is a **RED** adjusting nut. When this **RED** nut is in highest position toward boiler there is no lost motion on drive rod. Stoker is now at full coal feed. Moving this **RED** nut down on the threads away from boiler, allows less feed in proportion to amount

of lost motion on driving rod. Turn **RED** nut CCW for less coal feed. Turn **RED** nut CW for more coal feed.

AIR ADJUSTMENT – Located under scroll on stoker unit. This is to be adjusted for proper combustion by means of loosening locking screws and setting air shutter in proper position. This air shutter will be adjusted by your installer with a draft gauge. (Air shutter is usually set ½ ways open.)

COLD WEATHER FIRE – When stoker unit is running steady (1/2 hour or longer of continuous operation) the upper portion of grate will have approximately 4" supply of fresh unburned black coal. Fire bed should extend down toward bottom of grate with bottom holding 2" dead ash. If fire bed is too small, increase coal feed. If fire is falling off grate, reduce coal feed. (See coal feed adjustment).

WARM WEATHER FIRE – Upper portion of grate where coal feeds in from hopper should have approximately 4" black unburned coal. The red-hot burning coals should be 1-1/2" to 2" in length. Remainder of grate should be covered with dead ash.

Typical Control Arrangement

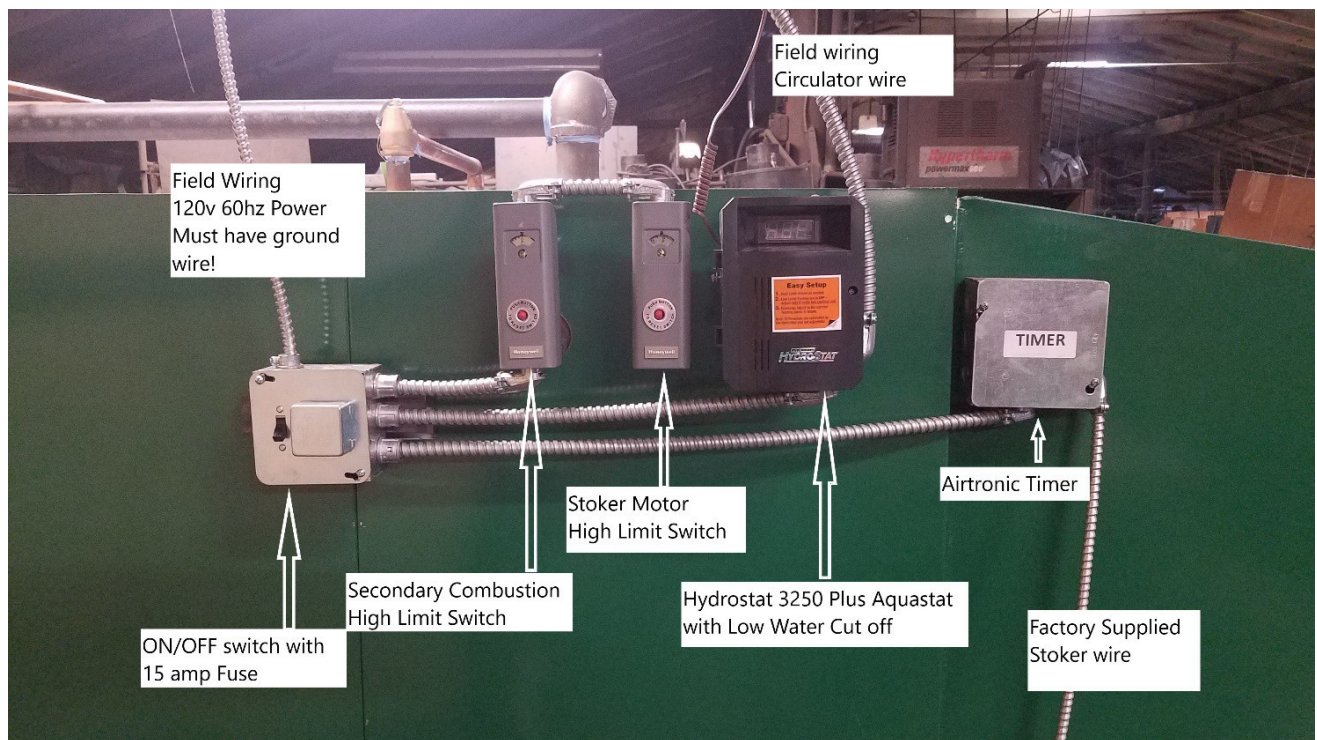

FIGURE 5

Setting Draft

Set draft through fire door on side of boiler. Here is a picture demonstrating placement of draft gauge or manometer. Refer to Page 11 for draft settings.



FIGURE 6

Setting Timer

To set timer you must first turn power to the boiler off, remove cover labeled timer. Timer is solid state and can be adjusted by moving switches on or off according to the switch value.

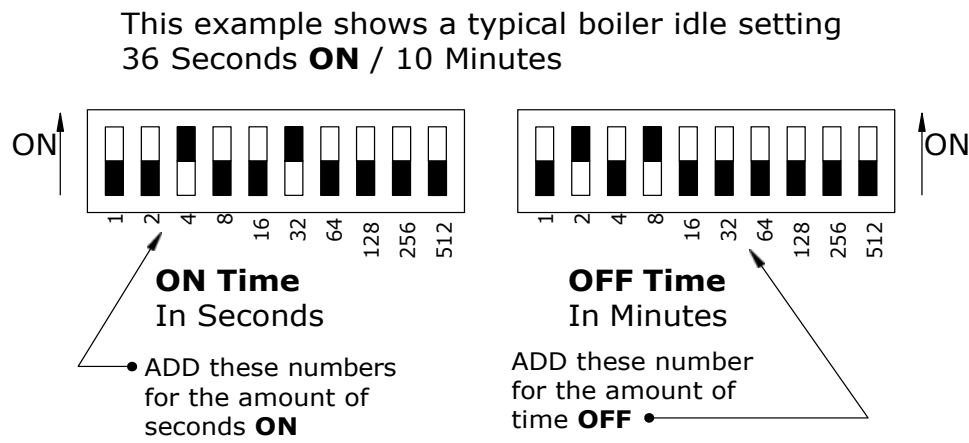

For wiring see diagram on page 26.

The timer has an indicator light. When the light is red N.O. (normally open) is powered. The Timer will be running the stoker unit at this time. When the indicator light on the timer is green N.O. is not Powered, If the boiler is up to temperature the stoker unit will not be running. When the boiler is up to operating temperature and the timer cycles it will turn the stoker unit on.

When the timer is first powered cycle will be ON and stoker unit will be powered.

Maintenance

Testing Controls and Safety Devices

Aquastat; To test aquastat boiler must be at operating temperature (between 160°-180°). Open cover on Hydrostat control, Test low limit by turning the knob marked low above the temperature of the boiler, stoker unit should kick on at this time. Turn low setting back to it's original setting, stoker unit should then shut back off. Testing high limit by turning the HI knob above the boiler temperature of the boiler. After the high limit has been turned up you must turn up room thermostat, at this time the stoker should kick on. Turn the thermostat down and set the high limit back to its original setting. If any of these tests fail the Hydrostat must be replaced.

Low water cut-off; To test the low water cut off, with stoker unit running press and hold the TEST button on top of the Hydrostat for 5 seconds. The display will read LCO. The low water light should illuminate and the burner circuit (B1 and B2) should de-energize and stoker will stop running. The boiler will restart after 5 seconds.

High limit switches with manual lock out; To test the high limit lock out switches insert a small flat headed screw driver into center hole on the cover and turn the dial down until the red button pops out at this time the stoker or secondary combustion fan will stop running. Press red button in to reset.

Safety pressure relief valve; Safety relief valve should be tested every 3 months. This can be done by lifting lever on the top of the relief valve. **Use extreme caution water will be HOT and under pressure**, lift lever slowly until some water is discharged, release lever and observe the

end of the discharge pipe. After a few minutes dripping should stop. If dripping does not stop relief valve will need to be replaced by a qualified plumber.

Cleaning & Lubrication of Boiler



Boiler exhaust pipe (stack pipe) must be cleaned at least once per year. On interior, keep area under baffles clear from ash and brush down inside of boiler in between baffles. Clean under grates annually by removing secondary combustion motor and vacuuming under grates or you may remove the bolt holding the grates and then remove the grate and proceed to vacuum. Grates must **then be re-cemented** back into their place. Upper portion of grates must be sealed (air tight) with furnace cement, from the upper portion of the grate (close to hopper) down to where the 1/8" holes are drilled in grates.



Lubricate large stoker motor (some may have sealed bearings). Oil secondary blower and circulator with a light grade of regular motor oil. Oil fire door and ash door hinges, to keep the hinges from seizing when not in use.



To minimize corrosion of boiler, it is recommended to run the system year-round. If shutting it down, it is important to clean boiler thoroughly at the end of heating season. Completely remove all coal from hopper. Remove and clean boiler pipe. Check chimney and base of chimney for obstructions or blockage. Clean under grate.

Ash Pan Emptying

To prevent toxic carbon monoxide gases from entering the home, certain precautions must be taken.



1. Ash pan must be emptied on a regular basis to prevent ashes from overflowing into ash pit area. Excessive ash accumulation may impede air flow to chimney, preventing gases to be drawn up chimney.



2. Fire door and ash door must be kept closed at all times during normal operation.
3. It is necessary to keep coal in hopper while boiler is in operation.
4. In most applications, it is sufficient to clean boiler and stack pipe once during heating season. However, under extreme weather conditions, or high demand on boiler running periods, the boiler and stack pipe may need more frequent cleaning. Clean as often as necessary.



CAUTION: ASH PAN IS HOT-Always Use Gloves to Remove Ash Pan



1. Before removing ash pan, turn switch off.
2. Open ash door.
3. Use a good pair of gloves, to remove ash pan.
4. Place filled ash pan on a non-combustible surface.
5. Slide an empty ash pan into boiler.
6. Close ash door.
7. Turn switch on.

Exhaust pipe (thru outside wall) should be cleaned when fan chamber is cleaned

Troubleshooting Guide

Problem	Cause	Fix
STOKER DOESN'T RUN	Main circuit breaker tripped	Reset
	Main fuse blown	Replace
	Fuse on stoker blown	Press reset button on motor
	Lo Water level (steam)	Fill boiler to proper water level
	High Limit maybe tripped	Reset High Limit switch
STOKER MOTOR GOES OUT ON RESET	Obstruction in throat of stoker	Empty hopper and clear obstruction
	Feed mechanism tight or corroded	Empty hopper and free-soak with penetrating oil. Use dry coal to prevent reoccurrence
	Motor or gear box defective	Replace
PRESSURE FLUCTUATES AND WATER OUT RELIEF VALVE	Expansion tank full of water Relief valve defective Defective valve in fill line	Drain – Close valve in pipe that goes from expansion tank to boiler. Drain tank dry. Close drain in expansion tank. Open valve in pipe to expansion tank. Put water pressure in boiler up to 12 to 15 lbs.
STOKER RUNS BUT DOESN'T FEED COAL	Feed nut backed off too far.	Increase feed-see preceding instructions.
	Obstruction in throat of stoker.	Empty hopper and remove obstruction.
	Feed mechanism tight or corroded	Empty hopper –free- use dry coal to prevent reoccurrence.
	Broken or slipping coupling	Replace
	Defective gearbox	Replace
	Feed mechanism out of adjustment	Throat bar height to be 1-3/4" to 2" (Part #11). Pusher bar (Part #12) to be approximately 3/4" behind the face (flat part) of throat bar when in its most forward position with feed nut (Part #19)
CIRCULATOR DOESN'T RUN	Lo limit setting in Triple Aquastat too high	Summer Set Lo at 140
	Boiler not up to temperature.	Winter 160
	Fire bed too small	Set Hi at 160 180 Increase coal feed to get bigger fire.
	Defective thermostat	Replace
	Circulator defective	Replace
CIRCULATOR RUNS BUT NO HEAT	Air in lines Pressure low.	Purge air from radiation Increase – 12 to 15 lbs. Check for leaks if pressure drops frequently.

Diagrams

Wiring Diagram - Boiler

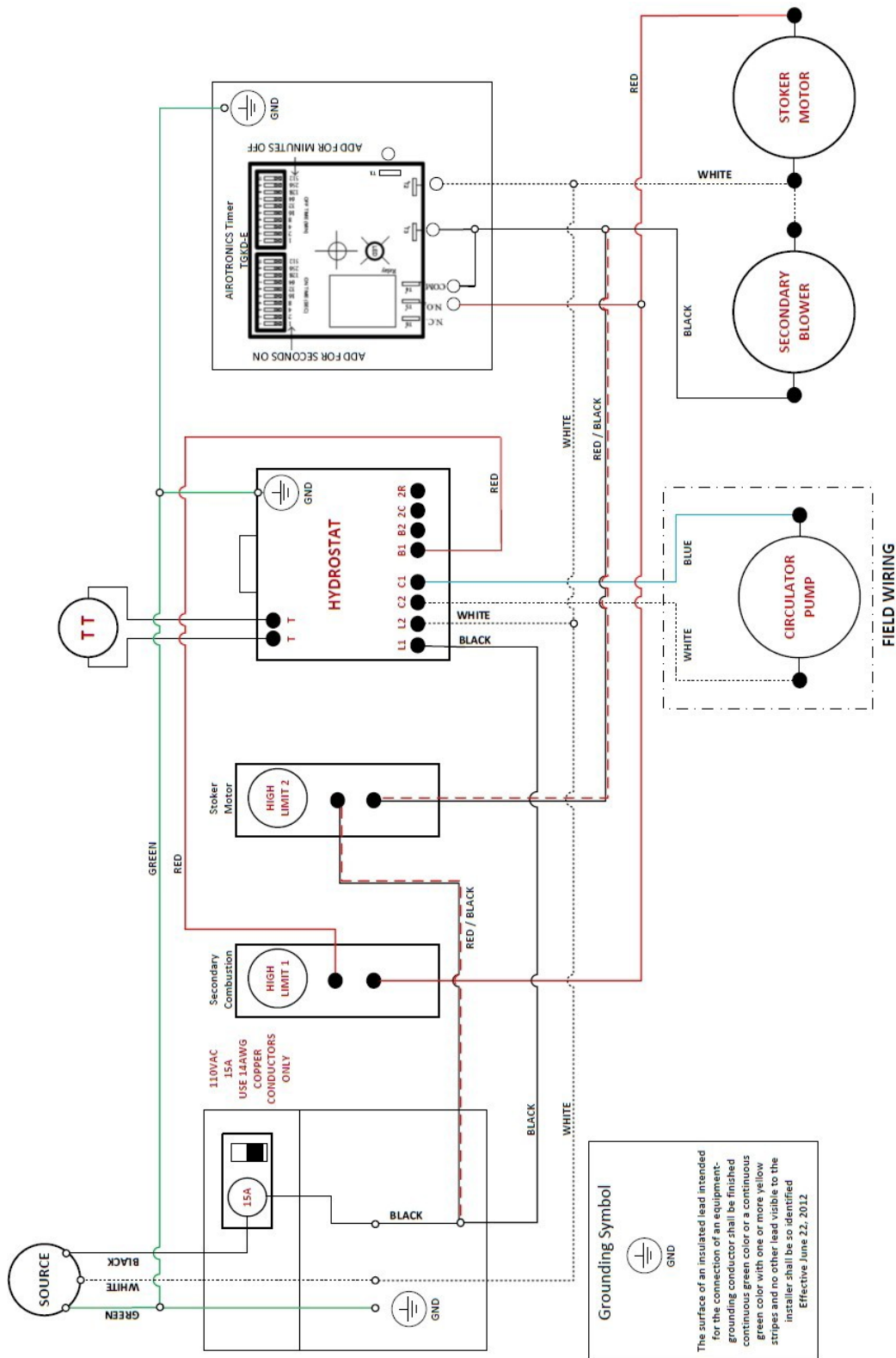

Wiring Diagram –Boiler: Oil & Coal Option

Attention: Firing this boiler with any fuel will void the UL listing. Boilers are tested for Anthracite coal **ONLY**

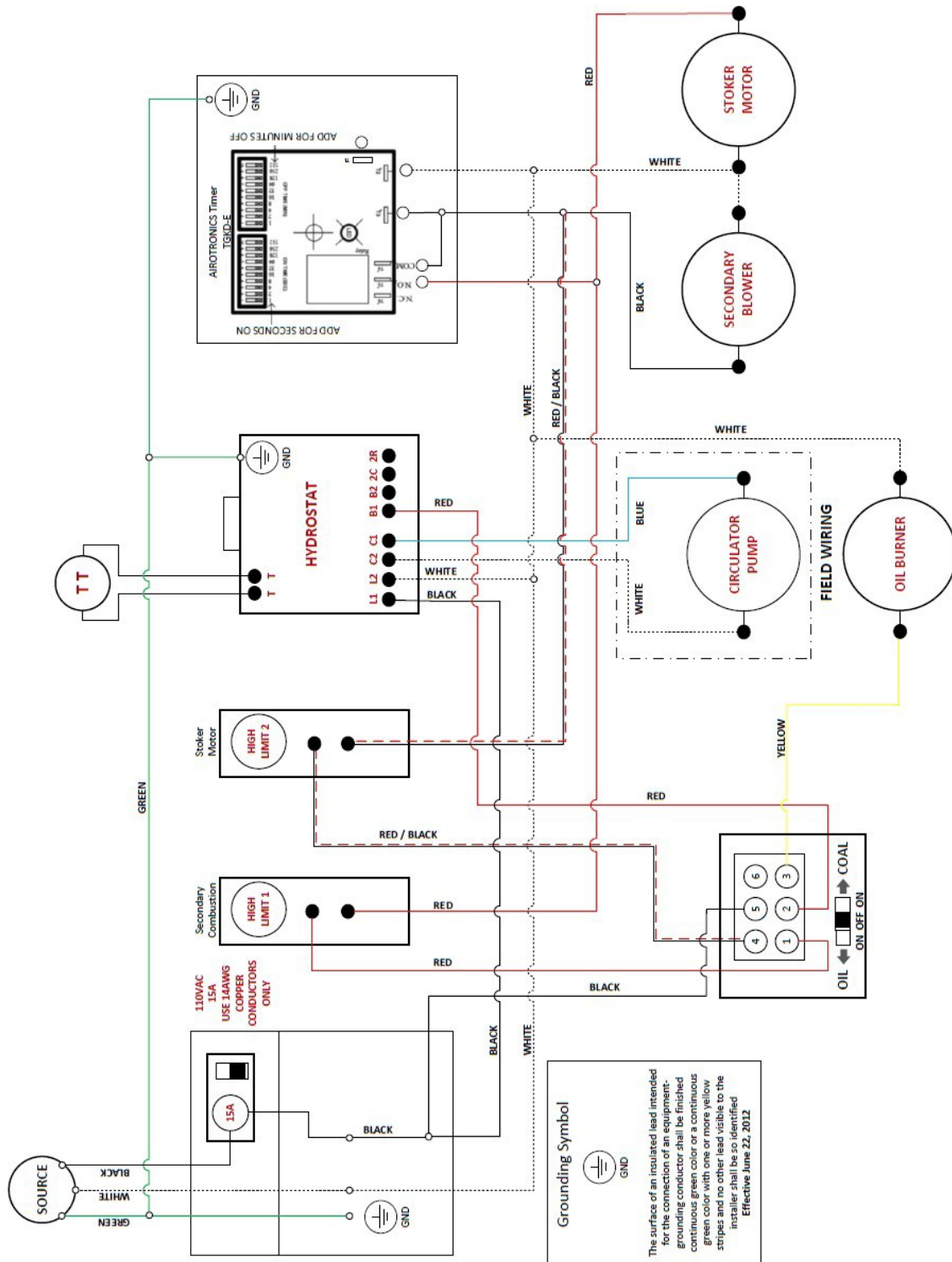

ISO Plumbing Diagram 1 - Boiler

1	Boiler	8	1-¼" x 1-¼" x 1" Tee	15	Hot Water Coil	22	Expansion Tank
2	1-¼" Supply Line	9	1-¼" Return Line	16	Cold Water to Coil	23	Tank Drain Valve
3	1-¼" x 1-¼" x 1" Tee	10	Circulator	17	Hot Water from Coil	24	Triple Acquastat Port
4	Flow Valve	11	Valves	18	Opt. Boiler Feed Port	25	Fire Door
5	1" x ½" F x 1" Tee	12	Return Line Port	19	Relief Valve	26	Ash Door
6	4006B Safety Control	13	Boiler Drain Valve	20	Altitude Gauge	27	Boiler Shims
7	By-Pass Loop	14	Stack Outlet	21	Valve to Exp. Tank		

NOTE:

1. CIRCULATORS CAN BE MOUNTED ON SUPPLY TO PUSH THROUGH THE SYSTEM OR THE RETURN TO PULL THROUGH THE SYSTEM

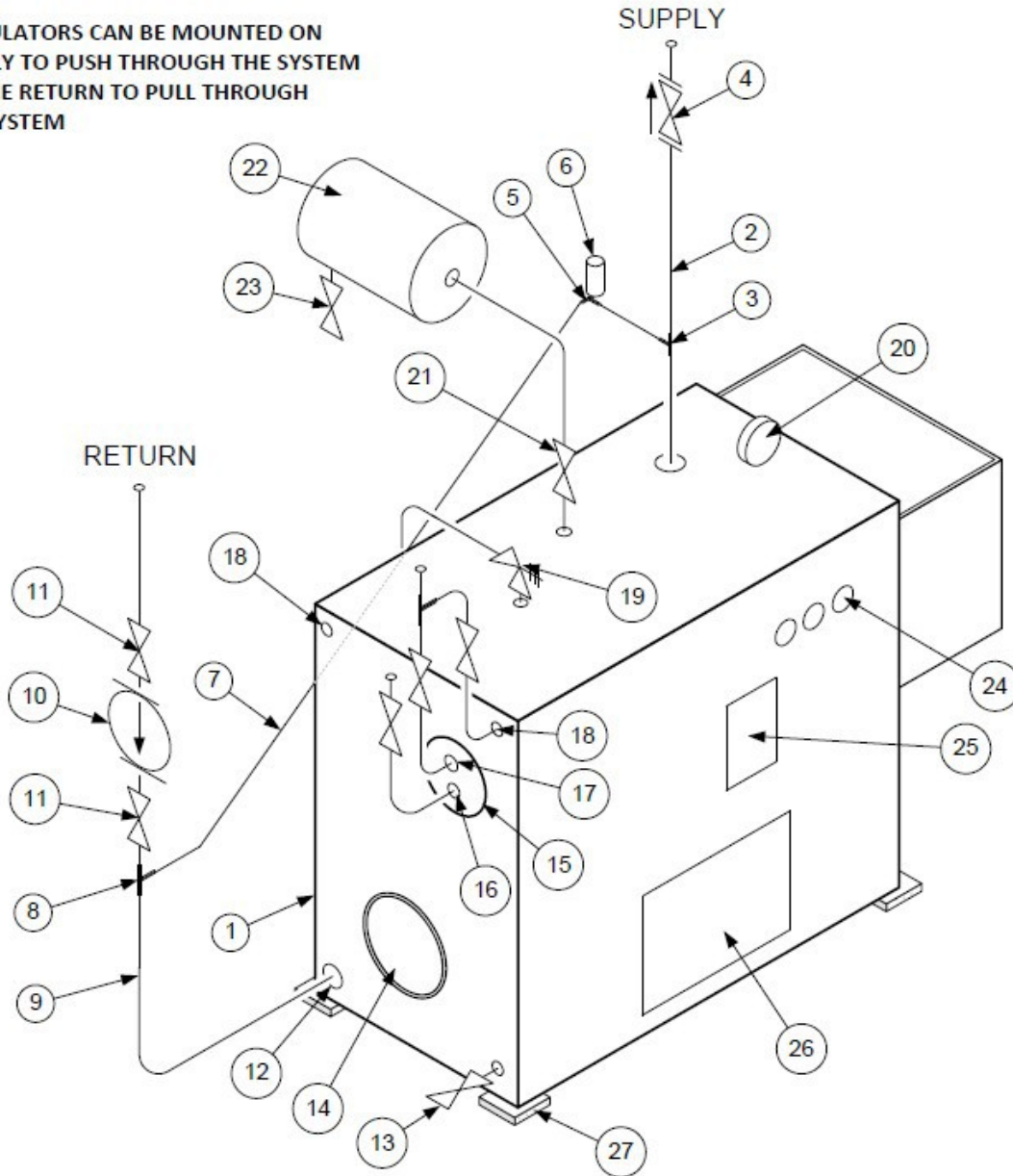

ISO Plumbing Diagram 2 – Dual Boilers

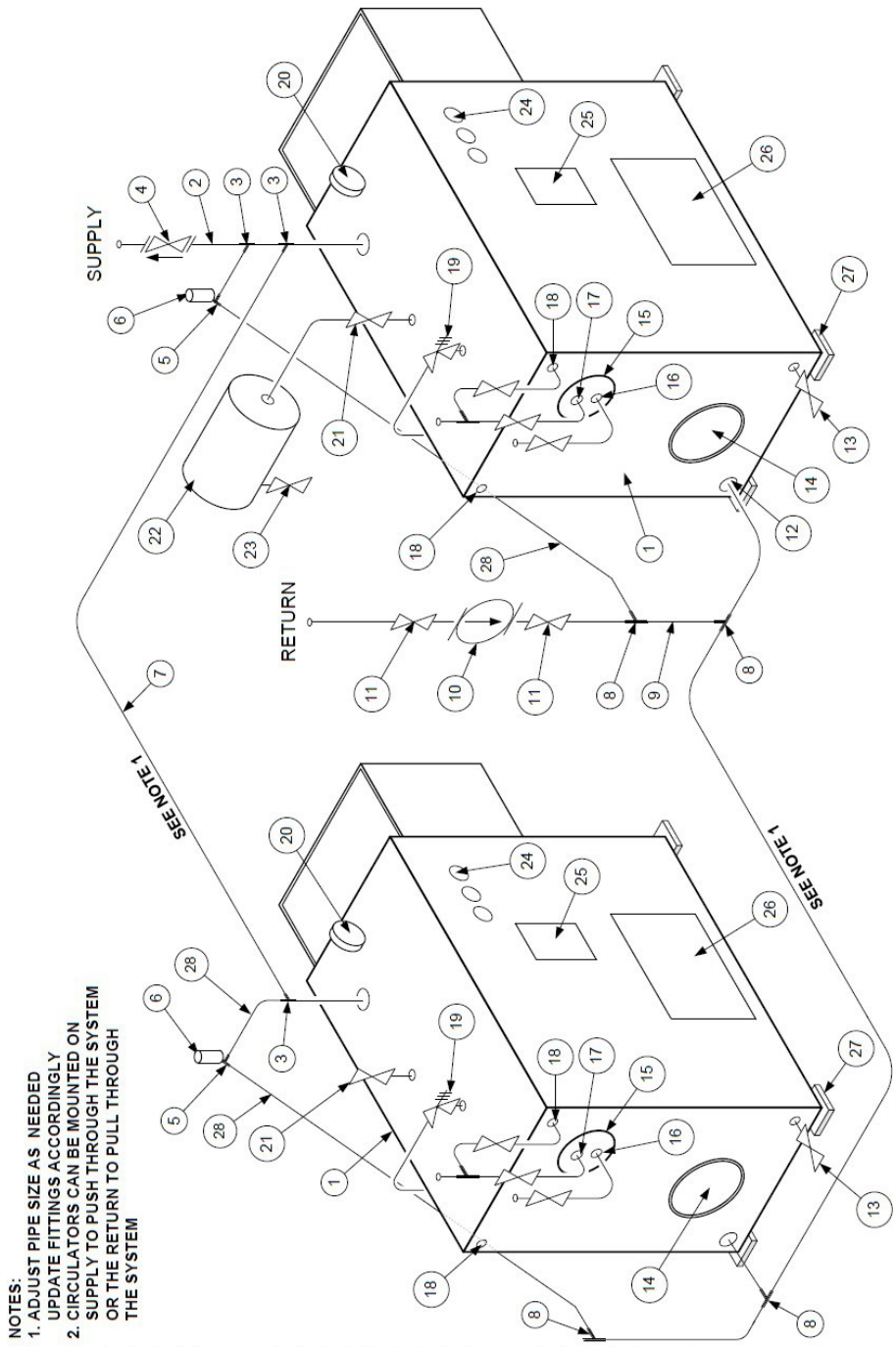

NOTES:
 1. ADJUST PIPE SIZE AS NEEDED
 UPDATE FITTINGS ACCORDINGLY
 2. CIRCULATORS CAN BE MOUNTED ON
 SUPPLY TO PUSH THROUGH THE SYSTEM
 OR THE RETURN TO PULL THROUGH
 THE SYSTEM

1	Boiler
2	1-1/2" Supply Line
3	1-1/4" x 1-1/2" x 1" Tee
4	Flow Valve
5	1" x 1/2" F x 1" Tee
6	4006B Safety Control
7	By-Pass Loop
8	1-1/4" x 1-1/2" x 1" Tee
9	1-1/2" Return Line
10	Circulator
11	Valves
12	Return Line Port
13	Boiler Drain Valve
14	Stack Outlet
15	Hot Water Coil
16	Cold Water to Coil
17	Hot Water from Coil
18	Opt. Boiler Feed Port
19	Relief Valve
20	Altitude Gauge
21	Valve to Exp. Tank
22	Expansion Tank
23	Tank Drain Valve
24	Triple Acquasat Port
25	Fire Door
26	Ash Door
27	Boiler Shims
28	1" Bypass Line

Typical Zone Valve Wiring Diagram - Boiler

SINGLE CIRCULATOR — Multiple Zone Valves including Indirect, No Zone Control Panel

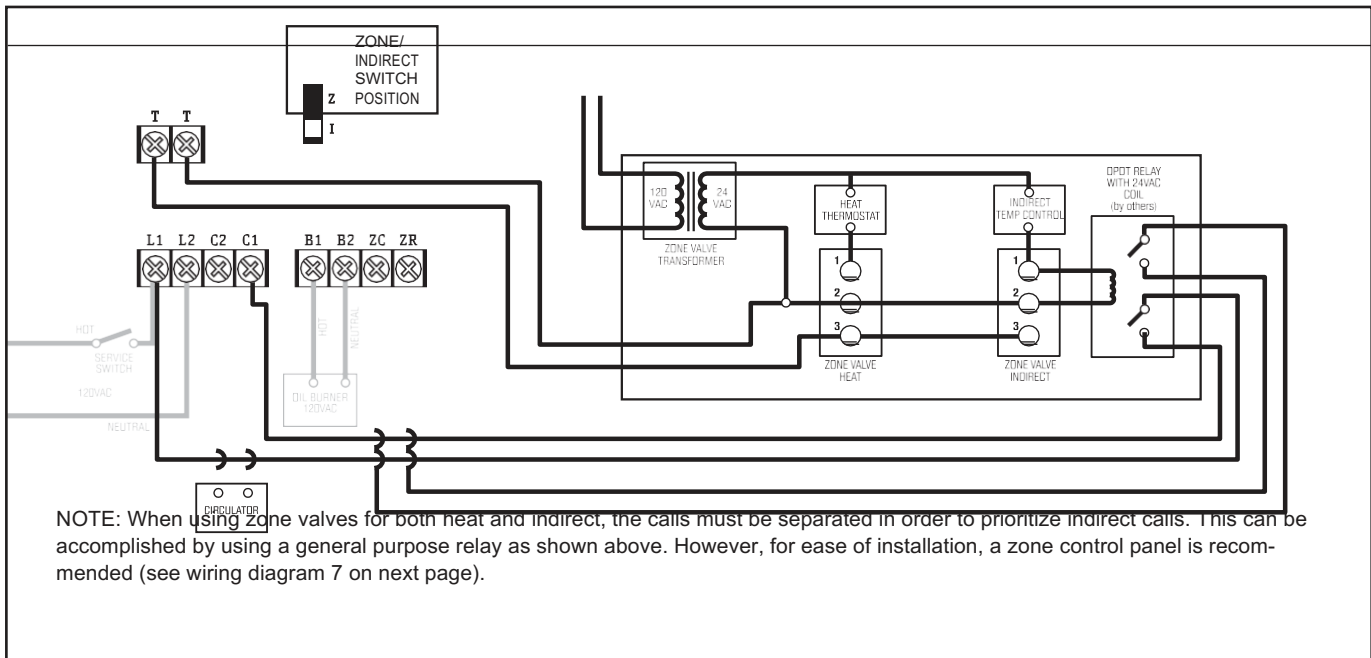

7 SINGLE CIRCULATOR — Typical Multiple Zone Valve Panel with Indirect

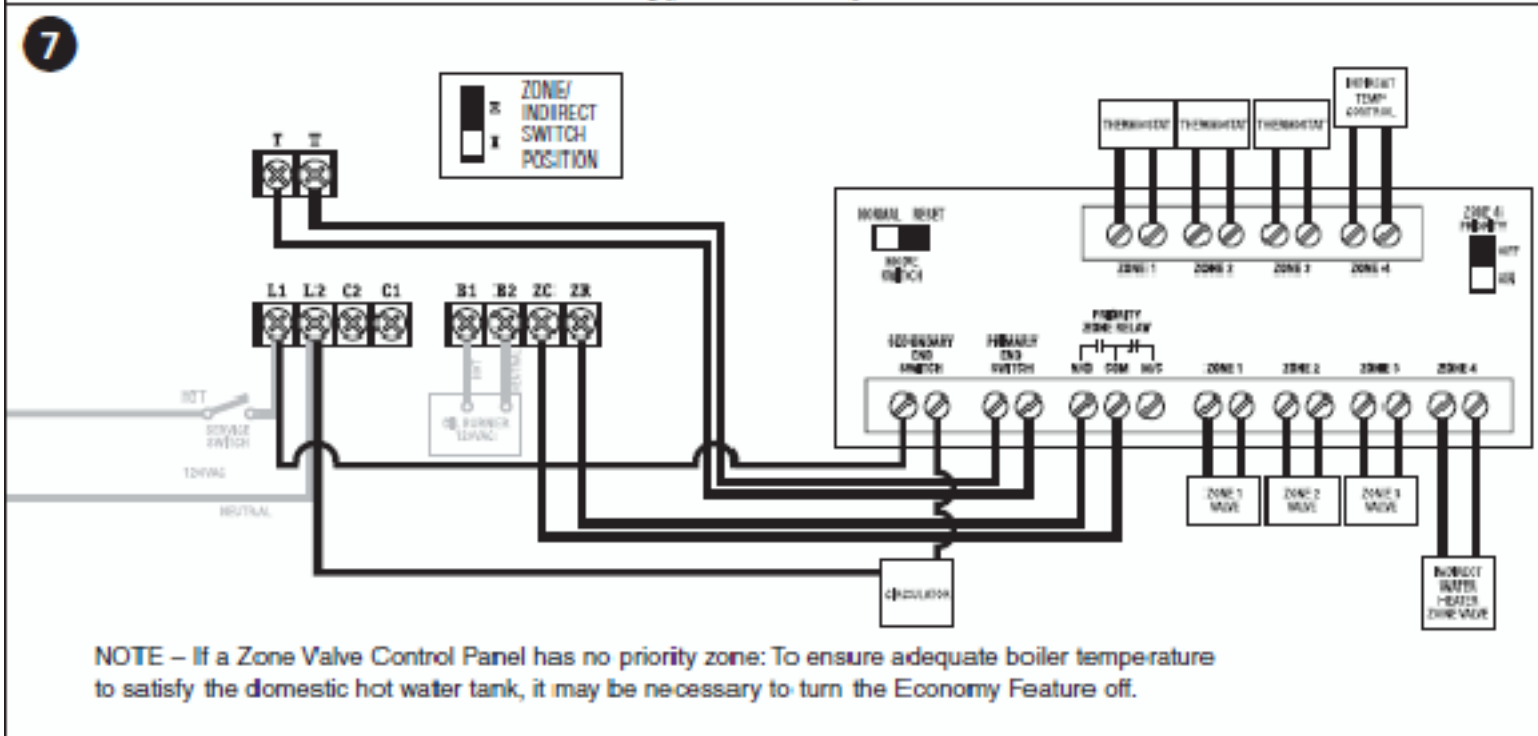

Boiler Major Components



This is a Left Handed boiler

Warranty

Keystone Manufacturing company extends the following warranties to the original owner from the date of purchase.

- Ten Years Workmanship on boiler body
- Two years on grates and side rails
- One year all electric controls and motors.
- Warranty does not apply if damage occurs because of improper handling, operation, abuse, rust, corrosion, misuse or use beyond rated capacity.
- This warranty does not apply if the product has been altered in any way after leaving the factory.
- All warranty claims should be made through dealer where the appliance was originally purchased. Model, **Stoker Unit** Number 1 ½ x 3 tag (found below hopper) and original copy of the sales receipt need be presented to dealer.
- If a consumer chooses to make a warranty claim directly through Keystone Manufacturing Company model, stoker unit number, and copy of the original sales receipt are required. Customer must provide a credit card which will be charged for the full retail price for the product plus shipping and handling. When defective part is returned to the company and found to be a defect within warranty period the consumer's credit card will be credited back the cost of part.
- Keystone Manufacturing Company assumes no responsibility for any labor expenses, for service, product removal, reinstallation or any freight charges for parts returned to the company.
- If defective in material or workmanship and if removed by the owner with in warranty period Keystone manufacturing will at their opinion repair or replace the product.
- This warranty is limited to defective parts, repair, or replacement at our opinion and excludes any incidental and consequential damages connected there with.
- Warranty exclusions, labor, door gasket, ash tub, hopper and paint



Boiler Information

Dealer / Phone #: _____

Date of purchase: _____

Stoker unit number: _____

Boiler Model: _____

Parts Ordering

If not listed above, locate the metal 1 ½" x 3" Keystoker label fastened to stoker unit body, near gear motor. The four or five-digit number will be required to get proper replacement parts from your dealer.

Boiler Contents Checklist

	Thermostat
	Relief Valve
	Pressure / Temperature Gauge
	4006H with Well
	4006H with Well
	4006B with Well
	Fire Door
	Draft Regulator
	Control with Well
	Instructions
	Warranty Card
	(2) 3/8" Stoker Bolts
	(2) 3/8" Nuts
	(6) 3/8" Washers
	(4) Hopper Washers
	Spring Handle
	Carbon Monoxide (CO) Detector
	Charcoal
	(2) 3/8" Hopper Bolts

Packed By: _____

